

## Speaker

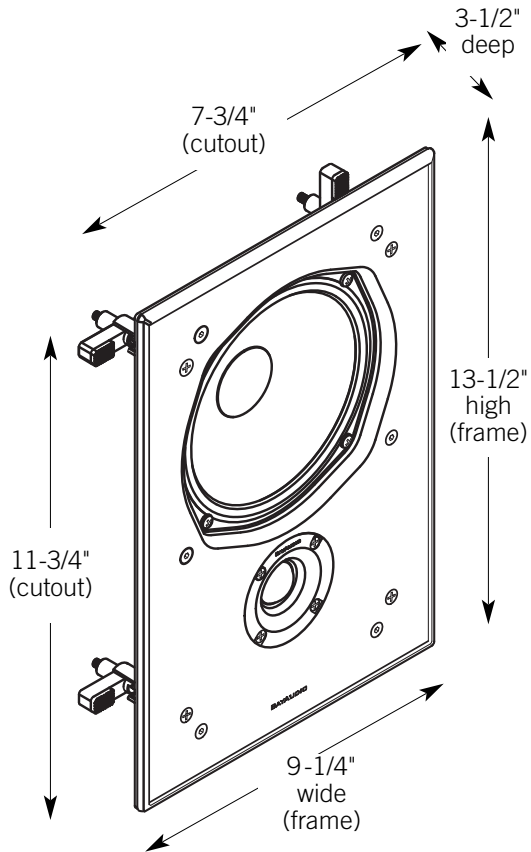

## Performance

### Placement

Walls and ceilings, horizontally or vertically.

### Maximum Output

100dB each with 100w

### Directed Dispersion

10° down from tweeter

### Room Size

Up to 3,000 ft<sup>3</sup>

### Close-Miked Near-Field Response (±3dB)

55-20,000 Hz

### 6dB Downpoint

45 Hz

### Nominal Coverage Angle (-6dB from Reference Axis)

60° H, 50° V

### Sensitivity [1 watt (2.83v) at 1m]

87dB

### Nominal Impedance

8 ohms

### Tweeter

1-inch silk dome

### Bass Unit

6-1/2" long-throw bass unit with poly cone, butyl surround.

### Network

TransientEdge® crossover topology.

### Connections

Spring-clips

### Construction

Damped plastic frame, Slot/Lock® mounting system.

### Grille

Custom perforated steel grille powder coated white. Paintable.

### Weight

7 lbs each

## Bracket

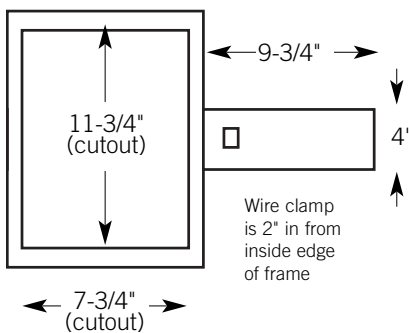

### BR60 Brackets

Metal rough-in brackets "claim the space" during drywalling. Removable arms can be mounted vertically or horizontally, and feature a wire clamp to hold cables in place during drywalling.

### BOX60 Back Box

Back boxes are 1/2" MDF. Include damping material and 4 metal brackets. Boxes reduce bleed-through in adjoining rooms by 9dB. Custom sizes available.

## Box60

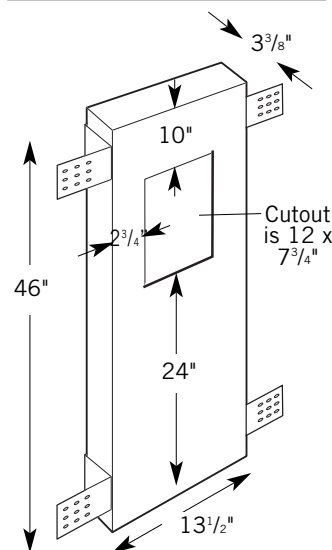

## Speaker

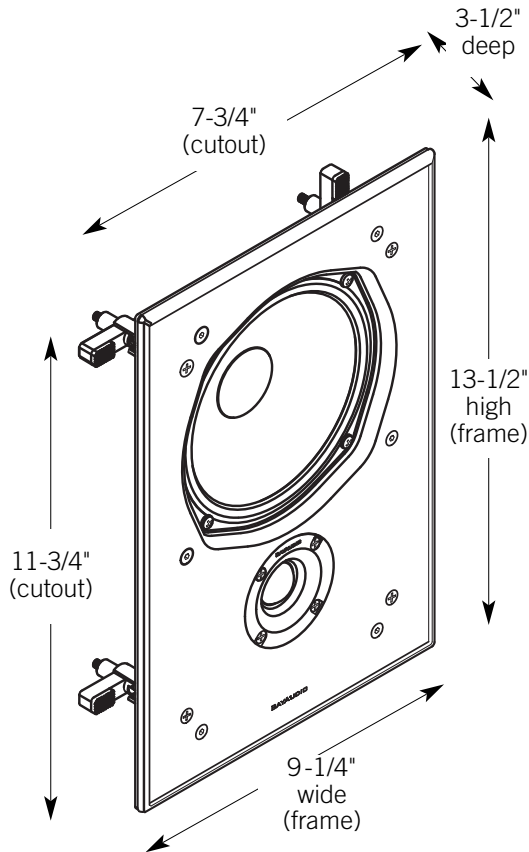

## Performance

### Placement

Walls and ceilings, horizontally or vertically.

### Maximum Output

104dB each with 100w

### Directed Dispersion

10° down from tweeter

### Room Size

Up to 3,000 ft<sup>3</sup>

### Close-Miked Near-Field Response (±3dB)

50-20,000 Hz

### 6dB Downpoint

40 Hz

### Nominal Coverage Angle (-6dB from Reference Axis)

60° H, 50° V

### Sensitivity [1 watt (2.83v) at 1m]

87dB

### Nominal Impedance

8 ohms

### Tweeter

1-inch silk dome

### Bass Unit

8" long-throw bass unit with poly cone, butyl surround.

### Network

TransientEdge® crossover topology.

### Connections

Compression push terminals accept bare wire to 12 gauge.

### Construction

Metalized plastic frame with blue damping gel, Slot/Lock® mounting system.

## Bracket

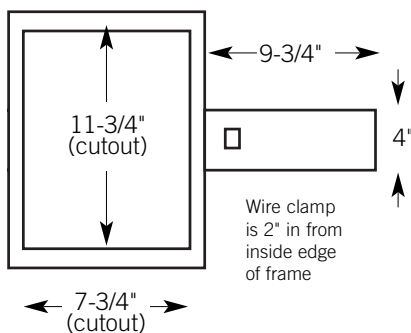

### BR60 Brackets

Metal rough-in brackets "claim the space" during drywalling. Removable arms can be mounted vertically or horizontally, and feature a wire clamp to hold cables in place during drywalling.

### BOX60 Back Box

Back boxes are 1/2" MDF. Include damping material and 4 metal brackets. Boxes reduce bleed-through in adjoining rooms by 9dB. Custom sizes available.

## Box60

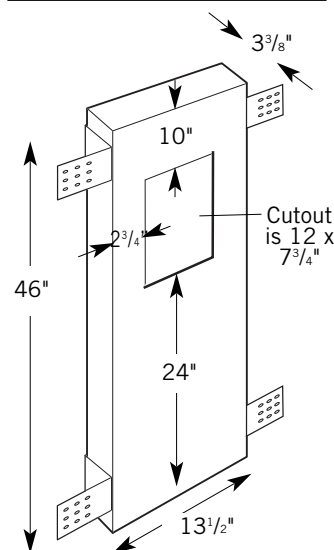

### Grille

Custom perforated steel grille powder coated white. Paintable.

### Weight

9 lbs each

## Dimensions and Bracket Information

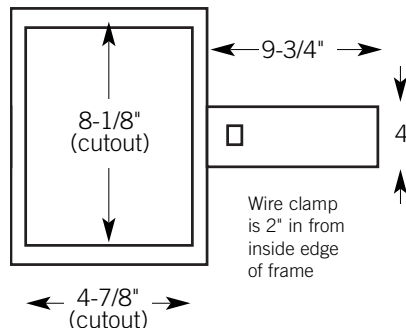
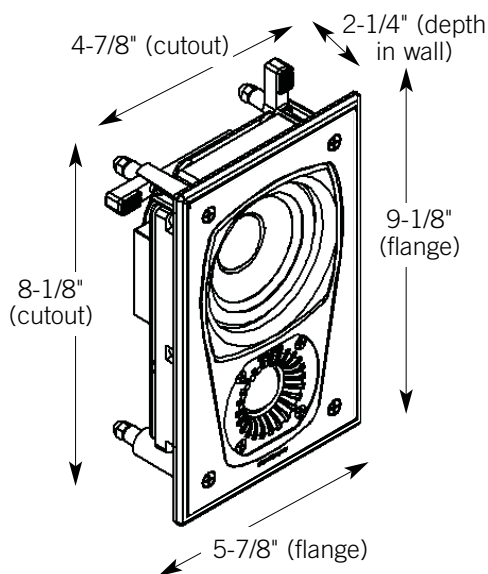

### Optional Rough-in Brackets

BR40 metal rough-in brackets are designed to "claim the space" during drywalling.

### Predicting Maximum SPL

What's loud enough? We think each speaker should produce 90dB (continuous) at the listening position. In most cases, there is an additive affect of 3dB with each additional speaker placed in the room. A pair of speakers capable of producing 90dB each will combine to produce 93dB.

## Performance

### Maximum Output

102 dB each, with 100 watts of amplification.

### Room Size

Up to 1,500 ft<sup>3</sup>

### Close-Miked Near-Field Response (-3dB)

58-20,000 Hz

### 6dB Downpoint

46 Hz

### Nominal Coverage Angle (-6dB from Reference Axis)

65° H, 60° V

### Sensitivity [1 watt (2.83v) at 1m]

82dB

### Nominal Impedance

8 ohms

### Tweeter

1" starburst silk dome

### Bass Unit

4" long-throw bass unit with aluminum cone, butyl surround.

### Network

TransientEdge® crossover topology.

### Connections

Compression push terminals accept bare wire to 12 gauge.

### Construction

Injection-molded aluminum frame; exclusive RockDust® driver platform, 1-inch MDF baffle, Slot/Lock® mounting system.

### Grille

Custom perforated steel grille powder coated white. Paintable.

### Weight

5 lbs each

## Predictive Placement

### SPL

How loud will one speaker play, in dB, with given amplifier power.

Amp Power	Distance from ceiling to ear level				
	3'	6'	9'	12'	15'
50 watts	99dB	97dB	95dB	94dB	93dB
100 watts	102dB	100dB	98dB	97dB	96dB

### Coverage

How wide is the diameter of the coverage pattern, assuming -3dB from reference, as distance increases.

	3'	6'	12'	24'
<b>Vertically</b>				
Up from tweeter (20°)	1.5'	2'	4.5'	7'
Down from tweeter (35°)	2'	4.5'	8.5'	17'
<b>Horizontally</b>				
Across (60°)	3.5'	7'	14'	28'

## Speaker

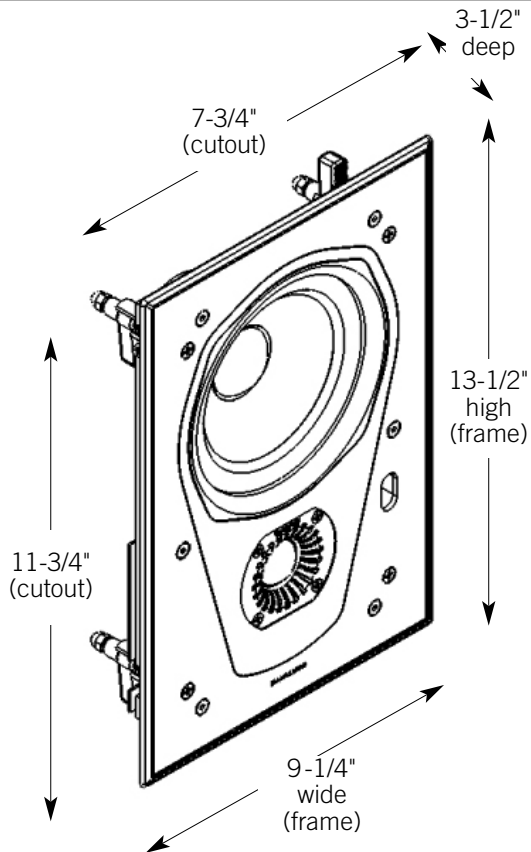

## Bracket

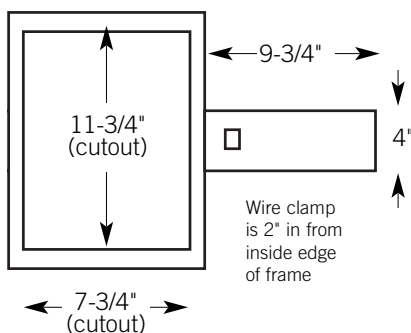

### BR60 Brackets

Metal rough-in brackets "claim the space" during drywalling. Removable arms can be mounted vertically or horizontally, and feature a wire clamp to hold cables in place during drywalling.

### BOX60 Back Box

Back boxes are 1/2" MDF. Include damping material and 4 metal brackets. Boxes reduce bleed-through in adjoining rooms by 9dB. Custom sizes available.

## Box60

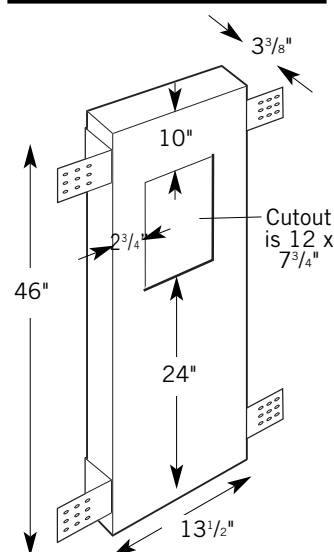

## Performance

### Placement

Walls and ceilings, horizontally or vertically.

### Maximum Output

106dB each with 100w

### Directed Dispersion

10° down from tweeter

### Room Size

Up to 3,000 ft<sup>3</sup>

### Close-Miked Near-Field Response (±3dB)

41-20,000 Hz

### 6dB Downpoint

36 Hz

### Nominal Coverage Angle (-6dB from Reference Axis)

65° H, 60° V

### Sensitivity [1 watt (2.83v) at 1m]

84dB

### Nominal Impedance

8 ohms

### Tweeter

1-inch Starburst silk dome

### Bass Unit

6-1/2" long-throw bass unit with aluminum cone, butyl surround.

### Network

TransientEdge® crossover topology. Pi Space tuning.

### Connections

Compression push terminals accept bare wire to 12 gauge.

### Construction

Injection-molded aluminum frame; exclusive RockDust® driver platform, 1-inch MDF baffle, Slot/Lock® mounting system.

### Grille

Custom perforated steel grille powder coated white. Paintable.

### Weight

8 lbs each

## Understanding Pi Space

### 2 $\pi$ Space

When you place an in-wall speaker in the middle of the wall, at least 3 feet from an adjoining wall, floor, or ceiling, it is considered to be in 2 $\pi$  Space.

### 1 $\pi$ Space

When you move the speaker within 3 feet of either an adjoining wall, floor, or ceiling, it is now in 1 $\pi$  Space. The adjoining wall increases the boundary effect on the speaker's output, increasing mid-bass and bass frequencies as much as 6dB. This will cause the speaker to sound muddy and heavy.

### Pi Space Diagram

This diagram shows the boundary effects of an adjoining wall and ceiling, and how these boundaries determine Pi Space. These are only recommendations. Set the Pi Space switch to your taste.

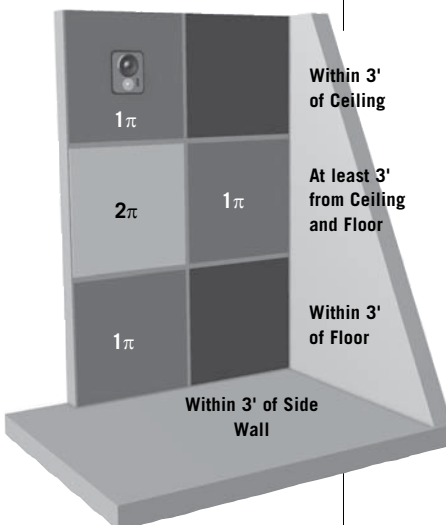

## Setting Controls

### Assymetrical Placement

You may encounter a situation where one in-wall speaker is placed near a side wall (1 $\pi$  Space) while the second speaker is placed in the middle of the room (2 $\pi$  Space). In this case, set each speaker according to its placement for a balanced presentation.

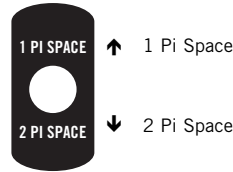

### Working With Directed Dispersion

The JM60's dispersion pattern has a distinctive 10° downward tilt from the tweeter (away from the bass unit). Because most in-wall speakers are placed at or above ear level in the wall, the JM60 will naturally fire away from the ceiling. If you are mounting the JM60 below ear level, invert the speaker so the tweeter faces up.

### Using With 900 Series Subwoofers

When using a subwoofer, run the JM60's through a high pass filter set to 80 Hz or above. This relieves the JM60's from playing bass information, plus dramatically improves power handling.

## Predictive Placement

### SPL

How loud will one speaker play, in dB, with given amplifier power.

### Full Range Performance

Amp Power	Distance from speaker to ear level			
	3'	6'	12'	24'
25 watts	105dB	100dB	97dB	93dB
50 watts	108dB	103dB	100dB	96dB
100 watts	111dB	106dB	103dB	99dB

### Coverage

How wide is the height and width of the coverage pattern, assuming -3dB from reference, as distance increases.

	Distance from speaker to ear level			
	3'	6'	12'	24'
<b>Vertically</b>				
Up from tweeter (20°)	1.5'	2'	4.5'	7'
Down from tweeter (35°)	2'	4.5'	8.5'	17'
<b>Horizontally</b>				
Across (60°)	3.5'	7'	14'	28'

## Speaker

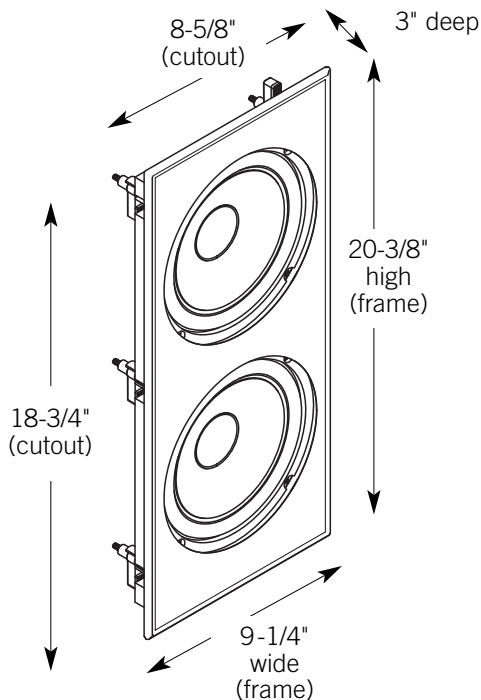

## Bracket

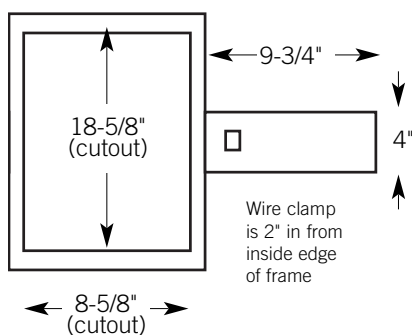

### BR70 Brackets

Metal rough-in brackets "claim the space" during drywalling. Removable arms can be mounted vertically or horizontally, and feature a wire clamp to hold cables in place during drywalling.

## Box70

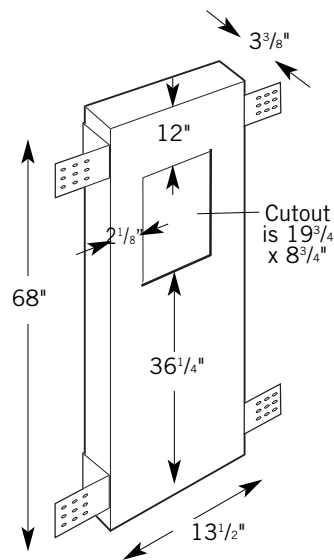

### Box70 Back Boxes

Back boxes are 1/2" MDF. Include damping material and 4 metal brackets. Boxes reduce bleed-through in adjoining rooms by 9dB. Custom sizes available.

### Building A Back Box

Our back box fits in normal 2x4 stud bays. You may choose to build a custom back box in walls deeper than 3-1/2" to achieve better bass control. The JAM In-Wall Subwoofer requires 1.2 ft<sup>3</sup> of air volume behind the wall to achieve full bass extension. Here are box-building dimensions with minimum depths to give your carpenter:

MDF Thickness	1/2"	3/4"
Width	14-1/2"	14-1/2"
Depth	4-1/2"	5"
Height	45"	47"

## Sub Classification

### Transitional Subwoofer

Bay Audio classifies three types of subwoofers:

#### Rumble Subs

Designed for bass from 15Hz through 30Hz in theaters.

#### Impact Subs

Designed for maximum pressure in the impact zone of 40Hz through 100Hz.

#### Transitional Subs

Designed for bass reinforcement from 50Hz and above, specifically for smaller rooms, or used in a transitional capacity with Impact subs.

## Performance

### Placement

Walls and ceilings, horizontally or vertically

### Maximum Output

107dB each

### 96dB Performance

Single subwoofer:

5,000 ft<sup>3</sup> room, corner loaded.

2,500 ft<sup>3</sup> room, placed more than 4' from a corner.

Stereo pair:

10,000 ft<sup>3</sup> room, corner loaded.

5,000 ft<sup>3</sup> room, placed more than 4' from a corner.

### Volume Consideration

Approximately one subwoofer for every 2,500 ft<sup>3</sup>

### Close-Miked Near-Field Response (±3dB)

32-200 Hz

### 6dB Downpoint

29 Hz

### Bass Unit

Dual 8-inch long-throw bass units.

### Construction

Injection-molded aluminum frame; 1-inch MDF baffle, Slot/Lock<sup>®</sup> mounting system.

### Connections

Compression push terminals accept bare wire to 12 gauge.

### Grille

Custom perforated steel grille powder coated white. Paintable.

### Weight

11 lbs each

## What's Loud Enough?

We like subwoofers to produce at least 96dB continuous (100dB for high-impact theaters) throughout their range at the listening position.

For background music systems, performance to 85dB is appropriate.

## Determining Room Volume

Room volume is Width x Length x Height of the primary listening room, plus a portion of the volume of any rooms that are connected. When placing a subwoofer in position 1, add 25% of the volume of Room B. In position 2, add 50%. In position 3 add 100% of room B.

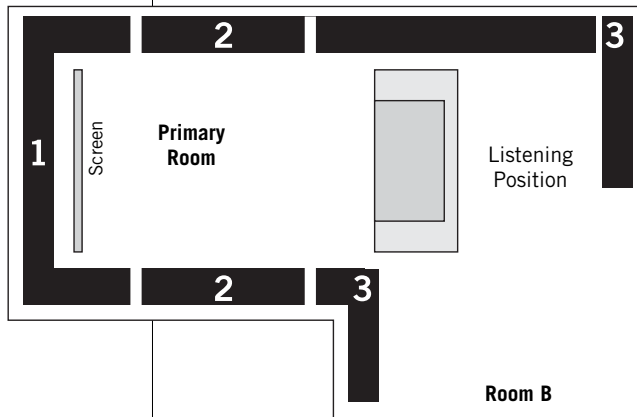

## Determining Output

### Corner Loaded SPL

Placing the JMSub low in a corner will yield the greatest bass output. Adding a second Sub adds 3 to 6dB of output, depending upon how close the subwoofers are to each other. The chart assumes the first subwoofer is placed in the corner, and the second is alongside a side wall.

Volume	First Sub	Second Sub
1,500 ft <sup>3</sup>	98dB	103dB
3,000 ft <sup>3</sup>	96dB	101dB
5,000 ft <sup>3</sup>	94dB	99dB
7,000 ft <sup>3</sup>	92dB	97dB

### Wall Loaded SPL

Use these SPL charts when placing the JMSub at least 4 feet from the floor or an adjoining wall. This chart assumes both subwoofers are placed at least 4' from the floor and adjoining walls.

Volume	First Sub	Second Sub
1,500 ft <sup>3</sup>	93dB	98dB
3,000 ft <sup>3</sup>	91dB	96dB
5,000 ft <sup>3</sup>	89dB	94dB
7,000 ft <sup>3</sup>	87dB	92dB

## Dimensions

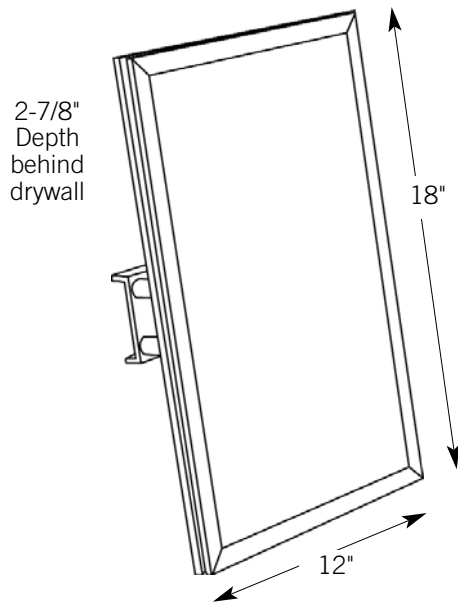

## Predictive Placement

### SPL

How loud will one speaker play, in dB, with given amplifier power.

Amp Power	Distance from ceiling to ear level			
	3'	6'	9'	12'
25 watts	96dB	91dB	88dB	84dB
50 watts	99dB	94dB	91dB	87dB
100 watts	102dB	97dB	94dB	90dB

### Coverage

With a 160° coverage angle, the LW1218 essentially plays throughout the room.

## LW1218-Bracket

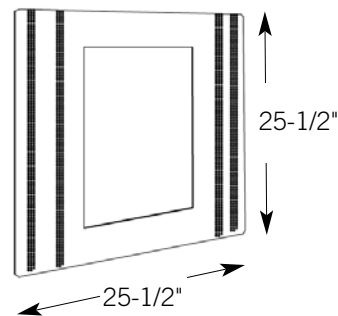

### LW1218-Bracket (optional)

Use for new construction. Bracket attaches directly to studs.

## LW1218-BOX

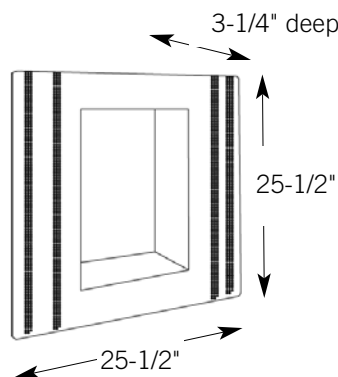

### LW1218-Box (optional)

Metal back boxes are plenum rated. Includes extensive damping material. Boxes reduce bleed-through in adjoining rooms by 9dB. Back box causes a slight decrease in bass extension.

## Performance

### Placement

Ceilings, walls, soffits. The LW1218 is weather-resistant, and can be placed in environmental extremes, including saunas and outdoors.

### Maximum Output

102dB each, with 100 watts of amplification.

### Soundfield Size

Up to 1,500 ft<sup>3</sup>

### Close-Miked Near-Field Response (-3dB)

65-20,000 Hz

### 6dB Downpoint

54 Hz

### Nominal Coverage Angle (-6dB from Reference Axis)

160° Radial

### Sensitivity [1 watt (2.83v) at 1m]

84dB

### Nominal Impedance

8 ohms

### Drive Unit

Full range 12x18" flat diaphragm driven by a neodymium motor structure

### Connections

Butt connectors

### Construction

Extruded aluminum frame, woven fiberglass diaphragm, aeronautic adhesives

### Weight

8 lbs each

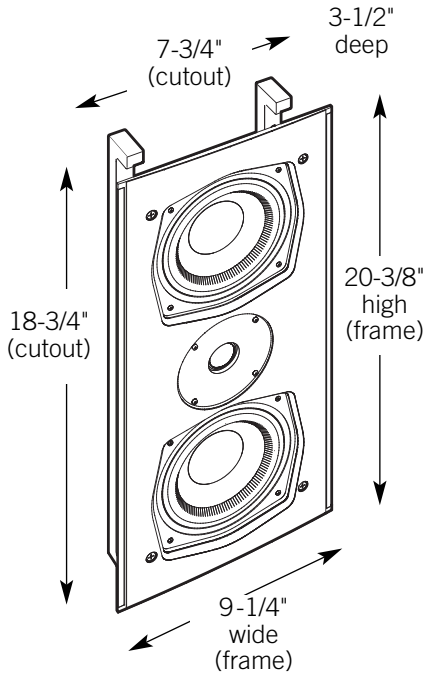

## Predictive Placement

### SPL

How loud will one speaker play, in dB, with given amplifier power.

Amp Power	Distance from speaker			
	3'	6'	12'	24'
50 watts	117dB	112dB	109dB	105dB
100 watts	120dB	115dB	112dB	108dB

### Coverage

How wide is the height and width of the coverage pattern, assuming -3dB from reference, as distance increases.

	Distance from speaker			
	3'	6'	12'	24'
<b>Vertically</b>				
On tweeter (30°)	2'	4'	8'	16'
<b>Horizontally</b>				
Across (60°)	3'	6'	12'	24'

## Performance

### Placement

Vertically or Horizontally in wall

### Maximum Output

120dB each, with 100 watts of amplification

### Directed Dispersion

On tweeter axis

### Room Size

Up to 9,000 ft<sup>3</sup>

### Close-Miked Near-Field Response (±3dB)

65-20,000 Hz

### 6dB Downpoint

60 Hz

### Nominal Coverage Angle (-6dB from Reference Axis)

60° H, 30° V

### Sensitivity [1 watt (2.83v) at 1m]

92dB

### Impedance

8 ohms

### Tweeter

1-inch soft dome with bullet phase plug, self-chambered.

### Midrange

Dual 6-1/2" long-throw bass units with polymer cone, butyl surround.

### Network

Features Bay Audio TransientEdge caps®, hand-wound chokes.

### Connections

5-way terminals, accept spades as large as 5/16", pins, banana plugs, and bare wire to 12 gauge.

### Construction

Aluminum frame, floating grille, 1" MDF baffle.

### Weight

14 lbs each

## Bracket

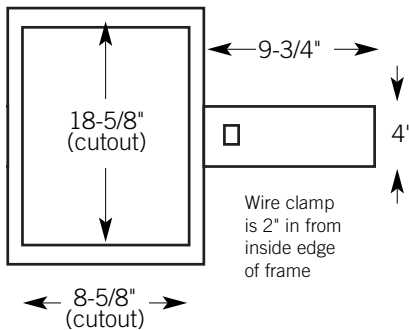

### BR70 Brackets

Metal rough-in brackets "claim the space" during drywalling. Removable arms can be mounted vertically or horizontally, and feature a wire clamp to hold cables in place during drywalling.

### BR70 Back Box

Back boxes are 1/2" MDF. Include damping material and 4 metal brackets. Boxes reduce bleed-through in adjoining rooms by 9dB. Custom sizes available.

## BoxPTM

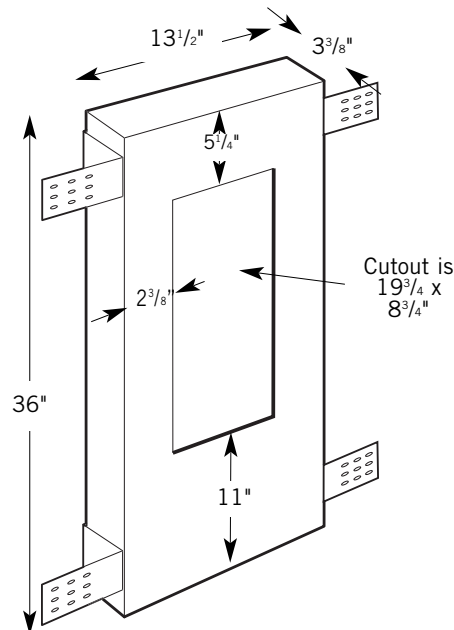

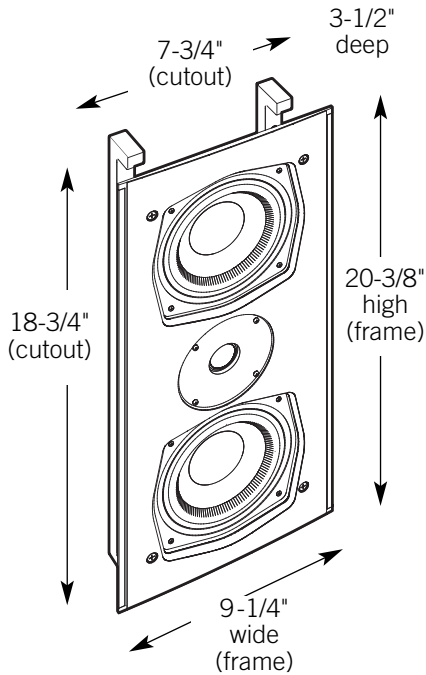

## Predictive Placement

### SPL

How loud will one speaker play, in dB, with given amplifier power.

Amp Power	Distance from speaker			
	3'	6'	12'	24'
50 watts	117dB	112dB	109dB	105dB
100 watts	120dB	115dB	112dB	108dB

### Coverage

How wide is the height and width of the coverage pattern, assuming -3dB from reference, as distance increases.

	Distance from speaker			
	3'	6'	12'	24'
<b>Vertically</b>				
On tweeter (30°)	2'	4'	8'	16'
<b>Horizontally</b>				
Across (60°)	3'	6'	12'	24'

## Performance

### Placement

Vertically or Horizontally in wall

### Maximum Output

120dB each, with 100 watts of amplification

### Directed Dispersion

On tweeter axis

### Room Size

Up to 9,000 ft<sup>3</sup>

### Close-Miked Near-Field Response (±3dB)

65-20,000 Hz

### 6dB Downpoint

60 Hz

### Nominal Coverage Angle (-6dB from Reference Axis)

60° H, 30° V

### Sensitivity [1 watt (2.83v) at 1m]

92dB

### Impedance

8 ohms

### Tweeter

1-inch scanspeak tweeter.

### Midrange

Dual 6-1/2" long-throw bass units with polymer cone, die-cast basket, butyl surround.

### Network

Features Bay Audio TransientEdge caps®, hand-wound chokes.

### Connections

5-way terminals, accept spades as large as 5/16", pins, banana plugs, and bare wire to 12 gauge.

### Construction

Aluminum frame, floating grille, 1" Corian baffle.

### Weight

20 lbs each

## Bracket

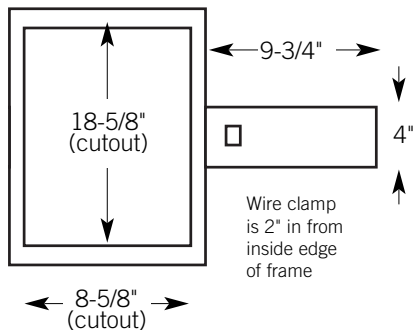

### BR70 Brackets

Metal rough-in brackets "claim the space" during drywalling. Removable arms can be mounted vertically or horizontally, and feature a wire clamp to hold cables in place during drywalling.

### BR70 Back Box

Back boxes are 1/2" MDF. Include damping material and 4 metal brackets. Boxes reduce bleed-through in adjoining rooms by 9dB. Custom sizes available.

## BoxPTM

