

Dimensions

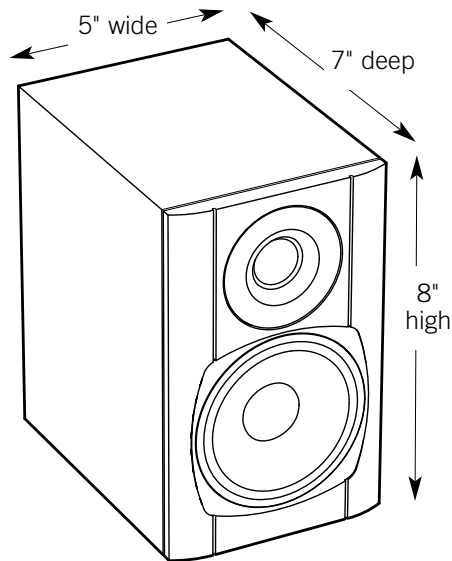

Predictive Placement

SPL

How loud will one speaker play, in dB, with given amplifier power.

Amp Power	Distance from speaker			
	3'	6'	12'	24'
50 watts	97dB	92dB	89dB	86dB
100 watts	100dB	95dB	92dB	89dB

Coverage

How wide is the height and width of the coverage pattern, assuming -3dB from reference, as distance increases.

	Distance from speaker			
	3'	6'	12'	24'
Vertically				
Up from tweeter (25°)	1.5'	3.5'	7'	14'
Down from tweeter (30°)	1.5'	2.5'	5'	10'
Horizontally				
Across (55°)	3'	6'	12'	24'

Performance

Placement

For bookshelves, stands, wall mounting. Vertical or horizontal orientation.

Maximum Output

102dB each, with 100 watts of amplification

Directed Dispersion

5° down from tweeter

Room Size

Full Range: Up to 1,500 ft³

Bandwidth Limited: Up to 2,500 ft³

Close-Miked Near-Field Response (±3dB)

68-20,000 Hz

6dB Downpoint

62 Hz

Nominal Coverage Angle (-6dB from Reference Axis)

55° H, 60° V

Sensitivity [1 watt (2.83v) at 1m]

83dB

Nominal Impedance

8 ohms

Tweeter

1-inch TCS neodymium soft dome.

Bass Unit

4" long-throw bass unit with aluminum cone, butyl surround.

Connections

Gold-plated terminals.

Cabinet Construction

Hardwood veneer on 1/2" MDF. 1/2" MDF bracing.

Optional Grilles

Soft Focus fabric grille.

Custom-cut metal grille. Add 1/2" to depth for grilles.

Optional Bracket

Fully articulating wall-mount bracket.

Weight

6 lbs each

Available Finishes

Standard Finish

Black paint on Ash veneer, white painted MDF

Finish Option

Cherry, maple veneer.

Custom Finish

Custom matched veneers, White or Black lacquer.

When Used In Theaters.

We designed the TC40 for bandwidth-limited use in small theaters (<1,500 ft³). Use two TC40's left and right, and the TC42 for the center channel.

When Used For Distributed Audio.

For best performance, use at least a 30w amplifier for the TC40's.

These speakers have a significant amount of bass for their cabinet size, and perform best with higher current amplifiers.

Dimensions

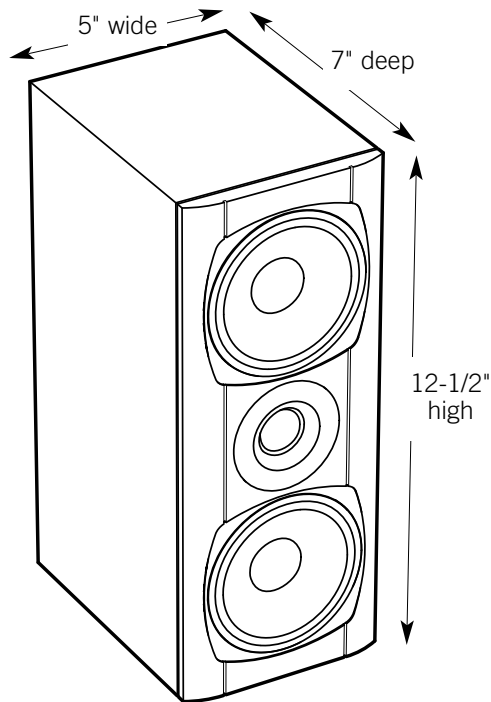

Predictive Placement

SPL

How loud will one speaker play, in dB, with given amplifier power.

Amp Power	Distance from speaker			
	3'	6'	12'	24'
50 watts	97dB	92dB	89dB	86dB
100 watts	100dB	95dB	92dB	89dB

Coverage

How wide is the height and width of the coverage pattern, assuming -3dB from reference, as distance increases.

	Distance from speaker			
	3'	6'	12'	24'
Vertically				
Up from tweeter (25°)	1.5'	3.5'	7'	14'
Down from tweeter (30°)	1.5'	2.5'	5'	10'
Horizontally				
Across (55°)	3'	6'	12'	24'

Performance

Placement

For bookshelves, stands, wall mounting. Vertical or horizontal orientation.

Maximum Output

104dB each, with 100 watts of amplification

Directed Dispersion

On tweeter

Room Size

Full Range: Up to 1,500 ft³

Bandwidth Limited: Up to 2,500 ft³

Close-Miked Near-Field Response (±3dB)

68-20,000 Hz

6dB Downpoint

62 Hz

Nominal Coverage Angle (-6dB from Reference Axis)

When placed horizontally: 60° H, 40° V

When placed vertically: 40° H, 60° V

Sensitivity [1 watt (2.83v) at 1m]

83dB

Nominal Impedance

8 ohms

Tweeter

1-inch TCS neodymium soft dome.

Bass Unit

Dual 4" long-throw bass units with aluminum cones, butyl surrounds.

Connections

Gold-plated terminals.

Cabinet Construction

Hardwood veneer on 1/2" MDF. 1/2" MDF bracing.

Optional Grilles

Soft Focus fabric grille.

Custom-cut metal grille. Add 1/2" to depth for grilles.

Optional Bracket

Fully articulating wall-mount bracket.

Weight

9 lbs each

Available Finishes

Standard Finish

Black paint on Ash veneer, white painted MDF

Finish Option

Cherry, maple veneer.

Custom Finish

Custom matched veneers, White or Black lacquer.

When Used In Theaters.

We designed the TC42 for bandwidth-limited use in small theaters (<1,500 ft³). Use two TC40's left and right, and the TC42 for the center channel.

When Used For Distributed Audio.

For best performance, use at least a 30w amplifier for the TC42's.

These speakers have a significant amount of bass for their cabinet size, and perform best with higher current amplifiers.

Dimensions

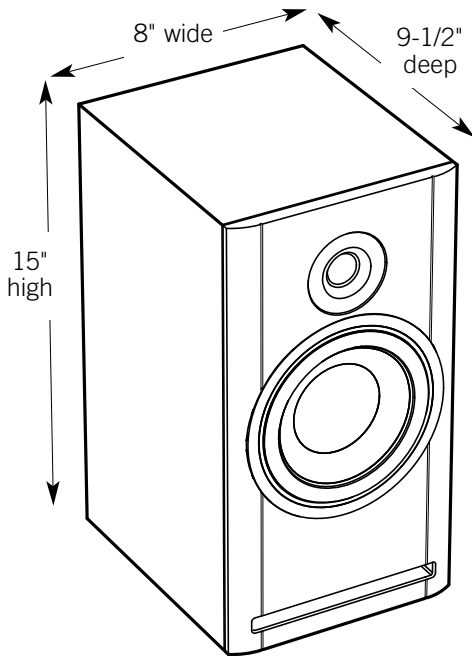

Predictive Placement

SPL

How loud will one speaker play, in dB, with given amplifier power.

Amp Power	Distance from speaker			
	3'	6'	12'	24'
50 watts	101dB	96dB	93dB	89dB
100 watts	104dB	99dB	96dB	92dB
150 watts	106dB	101dB	98dB	94dB

Coverage

How wide is the height and width of the coverage pattern, assuming -3dB from reference, as distance increases.

	Distance from speaker			
	3'	6'	12'	24'
Vertically				
Up from tweeter (25°)	1.5'	3'	6'	12'
Down from tweeter (30°)	1.5'	3.5'	7'	14'
Horizontally				
Across (60°)	3.5'	7'	14'	28'

Performance

Placement

For bookshelves, stands, wall mounting. Vertical or horizontal orientation.

Maximum Output

108dB each, with 100 watts of amplification

Directed Dispersion

5° down from tweeter

Room Size: Up to 3,000 ft³

Close-Miked Near-Field Response (± 3 dB)
40-20,000 Hz

6dB Downpoint

36 Hz

Nominal Coverage Angle (-6dB from Reference Axis)

60° H, 55° V

Sensitivity [1 watt (2.83v) at 1m]

84dB

Nominal Impedance

8 ohms

Tweeter

1-inch TCS neodymium soft dome.

Bass Unit

6-1/2" long-throw bass unit with polymer cone, butyl surround, shorting cylinder.

Connections

Gold-plated terminals.

Cabinet Construction

Hardwood veneer on 3/4" MDF. 3/4" MDF bracing.

Optional Grilles

Soft Focus fabric grille.
Custom-cut metal grille. Add 1/2" to depth for grilles.

Optional Bracket

Fully articulating wall-mount bracket.

Weight

19 lbs each

Available Finishes

Standard Finish

Black paint on Ash veneer, white painted MDF

Finish Option

Cherry, maple veneer.

Custom Finish

Custom matched veneers, White or Black lacquer.

When Used In Theaters.

We designed the TC60 for full-range use in mid-sized theaters (<3,000 ft³).

When Used For Distributed Audio.

For best performance, use at least a 50w amplifier for the TC60's. These speakers have a significant amount of bass for their cabinet size, and perform best with higher current amplifiers.

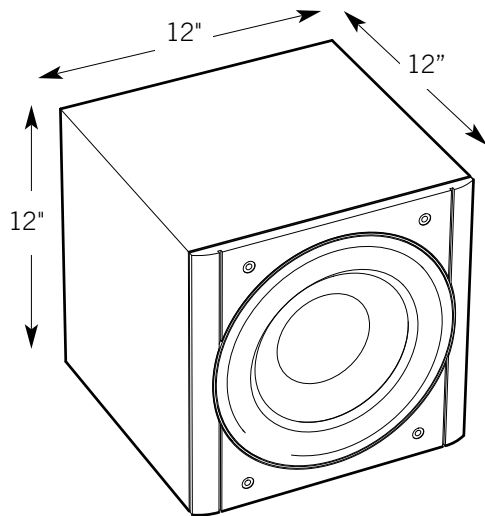

Performance

Placement

For freestanding or cabinet placement.

Maximum Output

111dB each

96dB Performance

Single subwoofer 6,000 ft³ room, corner loaded.
4,500 ft³ room, when placed in a cabinet.
Stereo pair 9,000 ft³ room, corner loaded.
6,500 ft³ room, when placed in a cabinet.

Volume Consideration:

Approximately one subwoofer for every 4,000 ft³

Close-Miked Near-Field Response (±3dB)

38-200 Hz

6dB Downpoint

32 Hz

Bass Unit

10-inch long-throw bass unit.

Amplifier

300 watt Class D amplifier. Does not require additional cooling when placed in cabinetry.

Controls

Gain, Low-pass from 40 to 160Hz, Variable Phase

Connections

Line level in and thru, speaker level in and thru.

Power

Auto/On/Off switch. Removable 3-prong power cord.

Cabinet Construction

Hardwood veneer on 3/4" MDF.

Firing Configuration

Fires forward

Weight

40 lbs each

Predictive Placement

Corner Loaded SPL

Placing the TC10 Subwoofer in a corner yields the greatest bass output. When using the Sub in a stereo pair, avoid placing both subs in corners. See Placement guidelines for more information.

Volume	1st Sub	2nd Sub
1,500 ft ³	111dB	116dB
3,000 ft ³	109dB	114dB
5,000 ft ³	107dB	112dB
7,000 ft ³	105dB	110dB

Cabinet Loaded SPL

Placing the Cube Sub in a cabinet, or alongside one wall.

Volume	1st Sub	2nd Sub
1,500 ft ³	108dB	113dB
3,000 ft ³	106dB	111dB
5,000 ft ³	104dB	109dB
7,000 ft ³	102dB	107dB

Adding a second TC10 Sub can add between 3 and 6dB of output, depending upon how close the subwoofers are to each other. The chart assumes both subwoofers are placed in a cabinet, or along side walls.

Placing Two Subwoofers

Use one TC10 Subwoofer to load the room with bass, use the second to shatter standing waves.

Corner placement

1. Place one subwoofer in a corner. Set phase, gain and low pass filters appropriately, until the system is balanced.
2. Walk the room listening for bass nulls and peaks.
3. Place the second subwoofer alongside a wall or in a cabinet.
4. Set the phase, gain, and low pass filters on the second subwoofer to dissipate the nulls and peaks.
5. Lower the gain on both subwoofers until they are balanced with the rest of the system.

Cabinet placement

1. Place both subwoofers in cabinet. Set phase, gain and low pass filters on one subwoofer, until the system is balanced.
2. Walk the room looking for bass nulls and peaks.
3. Set the phase, gain, and low pass filters on the second subwoofer, to dissipate the nulls and peaks.
4. Lower the gain on both subwoofers until they are balanced with the rest of the system.

Determining Room Volume

Room volume is Width x Length x Height of the primary listening room, plus a portion of the volume of any rooms that are connected. When placing a subwoofer in position 1, add 25% of the volume of Room B. In position 2, add 50%. In position 3 add 100% of room B. Adding a second Cube Sub can add between 3 and 6dB of output, depending upon how close the subwoofers are to each other. The chart assumes the first subwoofer is placed in the corner, and the second is alongside a side wall.

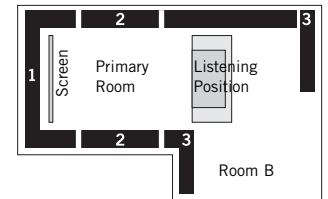

Controls

Setting The Low Pass Filter

If your preamplifier or processor features an electronic crossover, set the low pass filter to 200Hz. This disengages the sub's filter, avoiding cascading.

Setting Phase

Choose the phase setting which provides fuller bass. The TC10 Sub features variable phase so you can match the phase of the subwoofer with your mains. The simplest way to set phase is to use a Real Time Analyzer (for example, the Sencore SP295). Adjust the phase of the subwoofer until you achieve the smoothest frequency response. The easiest way to accurately set phase is by ear.

Setting The Crossover Point.

The TC10 Sub features a variable 24dB/octave low-pass filter. This reduces midrange bleed-thru and increases impact. This filter also allows more precise crossover setting.

Speaker Level Connections

Use Speaker Level In when connecting the subwoofer in parallel with a receiver that does not have a fully controllable Line Level Subwoofer Out. Some receivers have a fixed low-pass filter (typically at 80Hz) for Subwoofer Out. Avoid using Subwoofer Out in these cases — the fixed filter will not give you the flexibility you need to set the optimal crossover point for the subwoofer. In this case, run a parallel speaker level connection from the receiver's left and right mains into Speaker Level In. An internal summing circuit in the amplifier adds the bass from both channels into the subwoofer.

Auto/On/Off Switch

The auto sensing circuit is set to turn on in less than 1 second upon sensing a signal. The circuit stays on for 20 minutes after the signal is terminated.

Installation

Improving Theater Performance

Better quality AV Receivers and Processors allow you to set your mains to LARGE while using Subwoofer Out. Use the Bay Audio TC40 and TC42 in SMALL mode. Use the TC60 in LARGE mode, and allow the TC10 Subwoofer to receive all bass information (not just from the speakers set to SMALL).

If your AV Receiver only has a fixed Subwoofer Out setting, wire the TC10 subwoofers in parallel with your Left and Right mains, and set these speakers to LARGE. This allows you to run the Left and Right mains full range, crossing the subwoofer lower. This moves the crossover point below the critical midrange for better vocal and music definition.

Using Multiple Sources of Bass

The following chart shows frequency response in a test room (25x15x9') in the bass region, as measured from the listening position of a typical theater set-up. With one subwoofer producing bass, the room shows a dip of approximately 15dB at 55Hz. Running the subwoofer in parallel with the mains set to LARGE reduces the dip to approximately 9dB. Adding a second subwoofer while running the mains as LARGE decreases the dip to about 6dB — about as good a response as you'll be able to achieve without making substantial acoustic modifications to the room.

Using Multiple Subwoofers

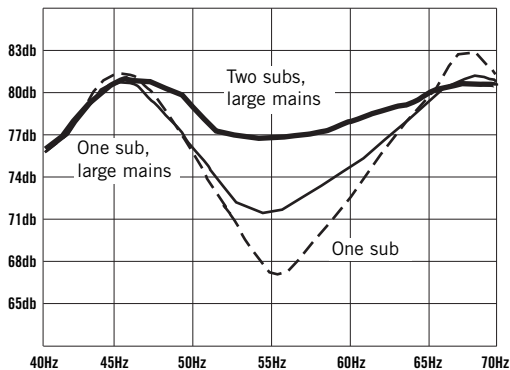

Setting Level

The TC10 Subwoofer does not rely upon an electronic limiting device for protection. While these devices help protect the driver from abuse, they reduce attack and musicality. Because we designed the TC10 Sub as a natural complement to the TC Series speakers, it exhibits the same quality of attack and musicality. Follow these directions to set the gain properly.

1. Set the low-pass filter to accommodate your electronics.
2. Turn the subwoofer off.
3. Turn on the main speakers at a high volume with demanding source material.
4. Turn on the subwoofer and set a rough balance to match the mains.
5. Turn off the mains, leaving only the subwoofer playing. Check for distortion. If you notice significant distortion (amplifier clipping or bottoming) do one or more of the following:
 - a. Reduce the gain
 - b. Set the low-pass filter lower
 - c. Add another subwoofer

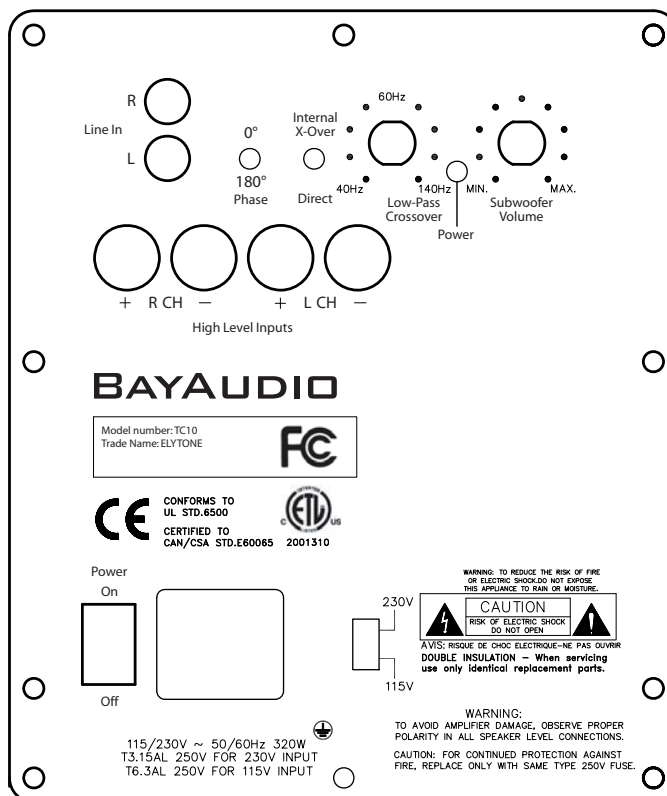

TC10 DownFiring Sub

Updated December 2007

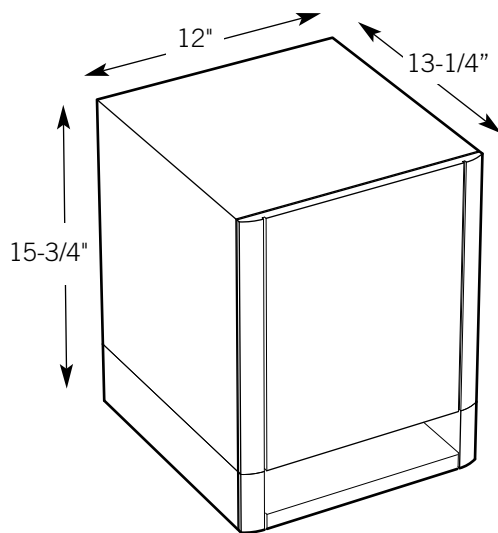

Tray Dimensions

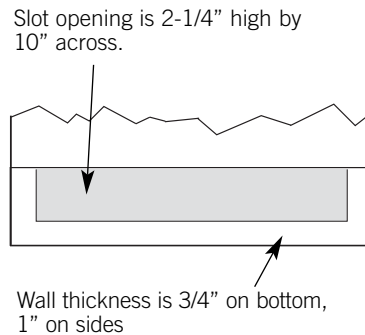

Performance

Placement

For freestanding or cabinet placement. Use the TC10 DownFiring sub when placed within a cabinet. The tray directs the output through a slot, improving transient attack, and reducing vibrations in the furniture.

Maximum Output

111dB each

96dB Performance

Single subwoofer 6,000 ft³ room, corner loaded.
4,500 ft³ room, when placed in a cabinet.

Stereo pair 9,000 ft³ room, corner loaded.
6,500 ft³ room, when placed in a cabinet.

Volume Consideration:

Approximately one subwoofer for every 4,000 ft³

Close-Miked Near-Field Response (±3dB)

38-200 Hz

6dB Downpoint

32 Hz

Bass Unit

10-inch long-throw bass unit.

Amplifier

300 watt Class D amplifier. Does not require additional cooling when placed in cabinetry.

Controls

Gain, Low-pass from 40 to 160Hz, Variable Phase

Connections

Line level in and thru, speaker level in and thru.

Power

Auto/On/Off switch. Removable 3-prong power cord.

Cabinet Construction

Hardwood veneer on 3/4" MDF.

Firing Configuration

Slot firing

Weight

50 lbs each

Predictive Placement

Corner Loaded SPL

Placing the TC10 Subwoofer in a corner yields the greatest bass output. When using the Sub in a stereo pair, avoid placing both subs in corners. See Placement guidelines for more information.

Volume	1st Sub	2nd Sub
1,500 ft ³	111dB	116dB
3,000 ft ³	109dB	114dB
5,000 ft ³	107dB	112dB
7,000 ft ³	105dB	110dB

Cabinet Loaded SPL

Placing the Cube Sub in a cabinet, or alongside one wall.

Volume	1st Sub	2nd Sub
1,500 ft ³	108dB	113dB
3,000 ft ³	106dB	111dB
5,000 ft ³	104dB	109dB
7,000 ft ³	102dB	107dB

Adding a second TC10 Sub can add between 3 and 6dB of output, depending upon how close the subwoofers are to each other. The chart assumes both subwoofers are placed in a cabinet, or along side walls.

Determining Room Volume

Room volume is Width x Length x Height of the primary listening room, plus a portion of the volume of any rooms that are connected. When placing a subwoofer in position 1, add 25% of the volume of Room B. In position 2, add 50%. In position 3 add 100% of room B. Adding a second Cube Sub can add between 3 and 6dB of output, depending upon how close the subwoofers are to each other. The chart assumes the first subwoofer is placed in the corner, and the second is alongside a side wall.

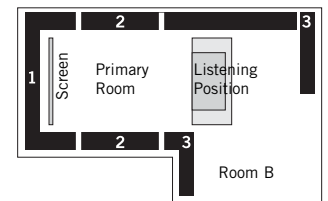

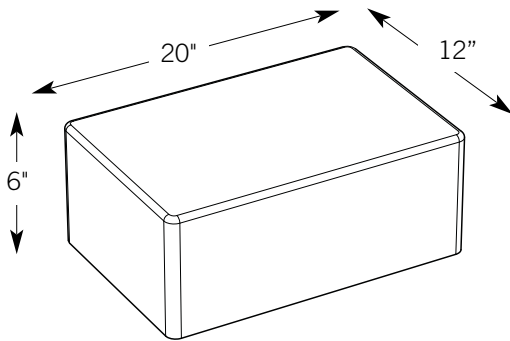

Performance

Placement

Under furniture.

Maximum Output

110dB each

96dB Performance

Single subwoofer 6,000 ft³ room, corner loaded.

4,500 ft³ room, when placed in a cabinet.

Stereo pair 9,000 ft³ room, corner loaded.

6,500 ft³ room, when placed in a cabinet.

Volume Consideration:

Approximately one subwoofer for every

4,000 ft³

Close-Miked Near-Field Response (±3dB)

38-200 Hz

6dB Downpoint

32 Hz

Bass Unit

10" driver

Optional Amplifier

500w on-board amplifier with Gain, Low-pass from 40 to 160Hz, Variable Phase, Line level in and thru, speaker level in and thru. Auto/On/Off switch.

Removable 3-prong power cord.

Cabinet Construction

Painted 3/4" MDF

Firing Configuration

Fires up

Weight

30 lbs each

Predictive Placement

Corner Loaded SPL

Placing the TC10 Subwoofer in a corner yields the greatest bass output. When using the Sub in a stereo pair, avoid placing both subs in corners. See Placement guidelines for more information.

Volume	1st Sub	2nd Sub
1,500 ft ³	111dB	116dB
3,000 ft ³	109dB	114dB
5,000 ft ³	107dB	112dB
7,000 ft ³	105dB	110dB

Cabinet Loaded SPL

Placing the Cube Sub in a cabinet, or alongside one wall.

Volume	1st Sub	2nd Sub
1,500 ft ³	108dB	113dB
3,000 ft ³	106dB	111dB
5,000 ft ³	104dB	109dB
7,000 ft ³	102dB	107dB

Adding a second TC10 Sub can add between 3 and 6dB of output, depending upon how close the subwoofers are to each other. The chart assumes both subwoofers are placed in a cabinet, or along side walls.

Determining Room Volume

Room volume is Width x Length x Height of the primary listening room, plus a portion of the volume of any rooms that are connected. When placing a subwoofer in position 1, add 25% of the volume of Room B. In position 2, add 50%. In position 3 add 100% of room B. Adding a second Cube Sub can add between 3 and 6dB of output, depending upon how close the subwoofers are to each other. The chart assumes the first subwoofer is placed in the corner, and the second is alongside a side wall.

